

# TT/TRT 2000 Series (175 HP) Powershift Cycling Transmission



## SPECIFICATIONS

General Rating+	
Input power max net	175 HP (130 kW)
Input torque max net	310 lb ft (420Nm)
Input speed max net	3000 rpm

+Rating may vary by vocation. Consult AVTEC Marketing Department for specific information.

## ROTATION

Input (viewed from input)	Right hand
Double Output (-1 model) (viewed from Input)	Right hand (forward ranges)
Single Output (-3 model) (viewed from Input)	Left hand (forward ranges)

## SPEEDS

	(-1 model) TT 2221/2421	(-1 model) TRT 2221/2421	(-3 model) TRT 2221/2421	(-3 model) TRT 2211/2411
Forward	4	4	4	2
Reverse	2	4	4	2

## MOUNTING

### DIRECT

SAE #3 dry converter housing with flex plate drive, 2 sides mounting pads and cradle mounting recommended.

### REMOTE

Trunion mounting at front and 2 side mounting pads.

## TORQUE CONVERTER

Type	2-phase, 4-element, twin turbine with automatic phase transition
Stall torque ratio	0.826:1 T, Ratio
	TT 240-5.44:1, TT 260-5.11:1, TT 445-4.92:1, TT 465-4.67:1, TT 270-6.97:1

GERAING

Type									
Range gears	Constant mesh, spur type, planetary								
Transfer gears	Constant mesh, spur type, in-line*								
	Forward		Reverse			Forward		Reverse	
Transmission/Model	Low	High	Low	High	Transmission/Model	Low	High	Low	High
TT 2221-1/ 2421-1	2.66:1	0.69:1	1.96:1		TRT 2221-3 /2 421-3	2.39:1	0.82:1	2.32:1	0.79:1
TT 2221-1/ 2421-1	2.02:1	0.69:1	1.96:1		TRT 2211-3 / 2411-3	2:39:1		2.32:1	
TT 2221-1/ 2421-1	2.15:1	0.56:1	1.58:1		TRT 2221-1 / 2421-1	2.02:1	0.73:1	1.96:1	0.71:1
TRT 2221-3 / 2421-3	6.61:1	2.39:1	6.39:1	2.32:1	TRT 2221-1 / 2421-1	1.64:1	0.59:1	1.55:1	0.57:1

\*Does not include Torque Converter ratio.

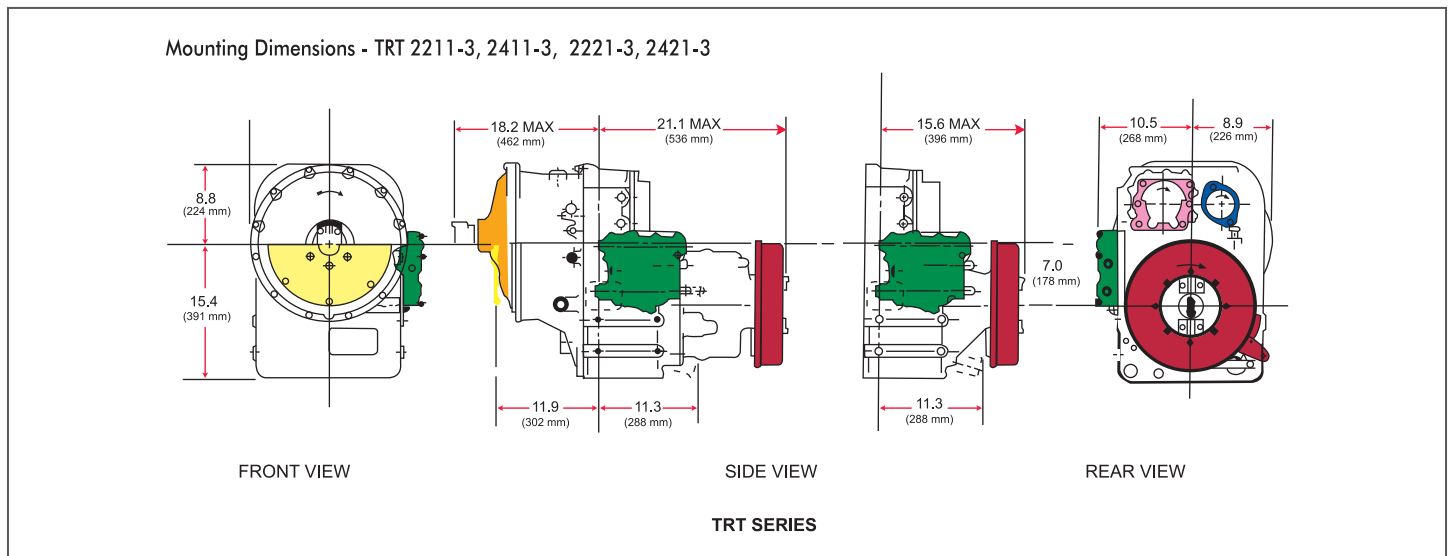
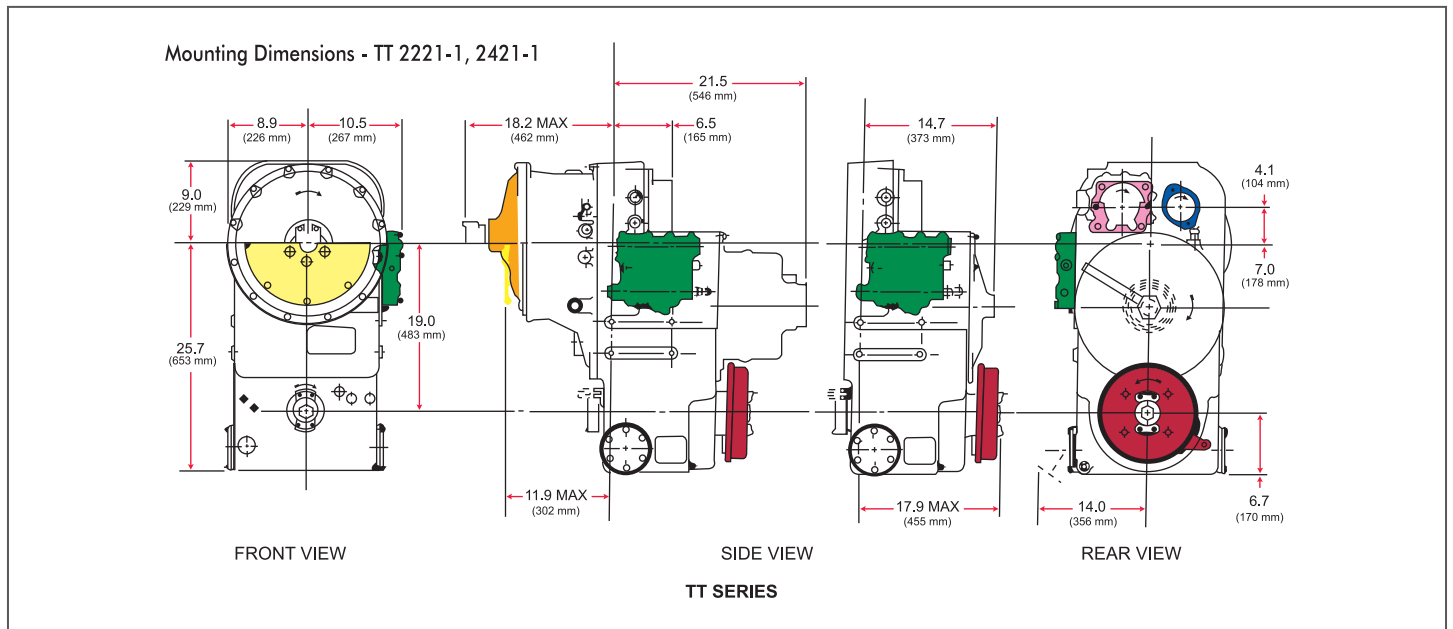

CLUTCHES

Hydraulically-actuated, spring released, oil-cooled, multidisc and automatically wear compensating.

## PARKING BRAKE (OPTIONAL)

	(-1 Models)	(-3 Models)
Type	Internal expandable shoe (Drum Brake)	Internal expandable shoe (Drum Brake)
Size	10 in x 1.5 in (254 mm x 38mm), Brake supplied unburnished,	13.4 in x 2 in (340 mm x 51 mm), Brake supplied unburnished
	Optional: Disc type caliper brake	

## POWER TAKEOFF PROVISION (OPTIONAL)

Implement pump drive	
Rating	110 hp (82 kW) max. intermittent power @ 2000 to 3000 rpm 90 hp (67 kW) max. continuous power @ 2000 to 3000 rpm
Mounting pads	SAE C 2/4 bolt; SAE B 2 bolt
Spline size	SAE C, B (reducer), SAE BB (1:1 ratio only)
Ratio	0.91 x engine speed (std); 1.00 x engine speed (optional)
Accessory drive	
Rating	30 hp (22kW) max. continuous power @ 2000 to 3000 rpm
Mounting pads	SAE A 2 bolt
Spline size	SAE A
Ratio	0.91 x engine speed (std); 1.00 x engine speed (optional)

## CONTROL VALVE BODY

Types	Mechanically actuated Hydraulic control or Electro Hydraulic
-------	--

## OIL SYSTEM

Oil type	Hydraulic Transmission fluid; type C-4 (Based on Ambient operating condition SAE oil grade needs to be selected)
Capacity (less external circuits)	-1 Model: 32 litres (8.5 U.S. gal); -3 Model: 25litres (6.5 U.S. gal)
Filter	Customer or AVTEC-PPD furnished remote mounted

## SIZE

Length, max. approx	Basic -1 Model	Basic -3 Model
TT Series	36.06 in (916 mm)	-
TRT Series	39.69 in (1008 mm)	39.26 in (997 mm)
Width, max. approx	19.36 in (492 mm)	19.36 in (492 mm)
Height, max. approx	34.70 in (881 mm)	24.23 in (615 mm)
Weight, max. approx	760to 935 lb (345 to 424 kg)	660 to 755 lb (299 to 342 kg)

## CUSTOMER BENEFITS

- Design Adaptability
- Smooth, Fast, Easy Operation
- High Productivity
- Lower Operating Cost
- Reduced Maintenance Cost
- Increased Availability
- Improved Operator Efficiency

## APPLICATIONS

- Front End Loaders
- Aircraft Towing Tractors
- Underground Tunneling Equipment - Low Profile Loaders
- Forklifts
- Mobile Cranes / Pick & Carry Cranes
- Winches
- Locomotives/Rail Bus/Track Inspection Car
- Empty Container Handling Reach Stacker / Tyre Handler

## DESIGN FEATURES AND OPTIONS

- Transmission direct or remote mounted
- Torqmatic® coupling
- Wet or dry direct engine mounting adaptations
- Choice of input and output flanges
- Parking barke
- Wet or dry implement pump drive splines
- Choice of accessory drive splines
- Magnetic speed pickup provision
- Neutral start provision
- Forward andreverse pressure taps
- Output disconnect arrangement
- Clutch cut-off-actuation: hydraulic or pneumatic

## SCAAN SPECIFICATION ASSISTANCE

To be sure that you get the most efficient engine transmission matching for your operation, with your preferred vehicle, AVTEC offers SCAAN. SCAAN stands for System for Computerized Application Analysis and helps eliminate guesswork from vehicle buying decisions. It can compute a wide variety of vehicle performance parameters. SCAAN will also check your powertrain specifications against AVTEC vocational experience to ensure satisfactory vehicle performance. SCAAN is user friendly. Interactive operation allows vehicle configurations to be quickly evaluated to ensure optimized powertrain selection.

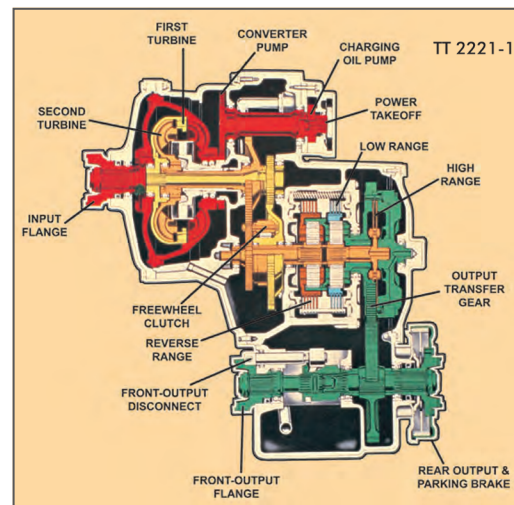
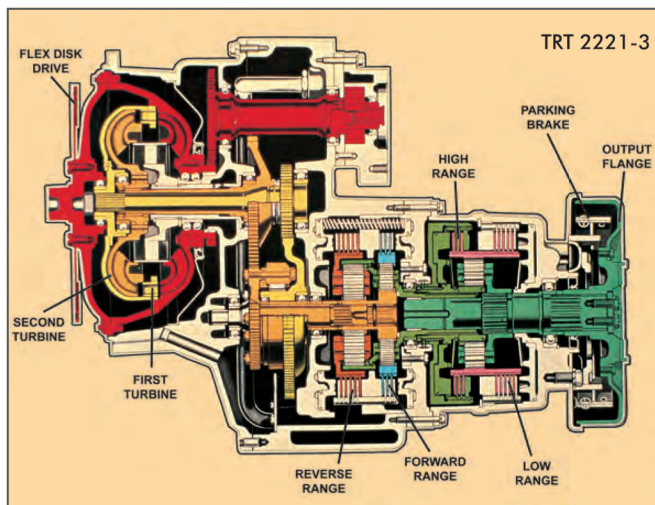

## PARTS AND SERVICE SUPPORT

- Prompt Professional Service
- Complementing parts availability is AVTEC's firm commitment to provide fast economical service